

aFLAT-Series

CRTtoLCD-5

Technical Manual	
Table of Contents	
1.0	General Information and Important Notes
1.1	Introduction
1.2	Technical Information Summary
1.3	Connectors
1.4	On Screen Display
1.5	Technical Specification
1.6	Supported Video Modes
1.7	Layout / Dimensions
1.8	Serial OSD
1.9	Technical Support
2.0	Revision History

1.0	User Information
	<p>Copyright 2005 by Kontron Embedded Modules GmbH. In this document Kontron Embedded Modules GmbH will also be referred to by the short form "Kontron Embedded Modules GmbH". The information in this document has been carefully checked and is believed to be accurate and reliable. However, no responsibility is assumed for inaccuracies. Furthermore, Kontron Embedded Modules GmbH reserves the right to make changes to any portion of this manual to improve reliability, function or design. Kontron Embedded Modules GmbH does not assume any liability for any product or circuit described herein.</p>
1.0	Trademarks
	<p>AT and IBM are trademarks of International Business Machines. XT, AT, PS/2 and Personal System/2 are trademarks of International Business Machines Corporation. Microsoft is a registered trademark of Microsoft Corporation. Intel is a registered trademark of Intel Corporation. All other products and trademarks mentioned in this manual are trademarks of their respective owners. The reproduction, transmission or use of this document or its contents is not permitted without expressed written authority. Offenders will be liable for damages. All rights created by patent grant or registration of a utility model or design, are reserved.</p>
1.0	General
	<p>For the circuits, descriptions and tables indicated no responsibility is assumed as far as patents or other rights of third parties are concerned. The information in the Technical Descriptions describes the type of the boards and shall not be considered as assured characteristics. The reproduction, transmission or use of this document or its contents is not permitted without express written authority. Offenders will be liable for damages. All rights, including rights created by patent grant or registration of a utility model or design, are reserved.</p>

1.0	Warranty
	<p>Each board is carefully and thoroughly tested before being shipped. If, however, problems should occur during the operation, please check your user specific settings of all boards included in your system. This is often the source of the fault. If a board is defective, it can be sent to your supplier for repair. Please take care of the following steps:</p> <ul style="list-style-type: none"> - The board returned should correspond to the factory default settings since a test is only possible under these settings. - In order to repair your board as fast as possible , we require some additional information from you. Please fill out the attached Repair Form and include it with the defective board. - If possible, the board will be upgraded to the latest version without additional cost. - Upon receipt of the board, please be aware that your user specific settings were changes during the test. <p>Within the guarantee, the repair is free as long as the guarantee conditions were kept. If no fault has been found, you will be charged with the test cost due to the high test expenditure. Repairs outside of the guarantee will be charged.</p> <p>This Kontron Embedded Modules GmbH product is warranted against defects in material and workmanship for our guaranteed warranty period from the date of shipment. During the warranty period, Kontron Embedded Modules GmbH will, at its option, either repair or replace products which prove to be defective.</p> <p>For warranty service or repair, the product must be returned to a service facility designated by Kontron Embedded Modules GmbH.</p> <p>The foregoing warranty shall not apply to defects resulting from improper or inadequate maintenance or handling by buyer, unauthorized modification or misuse, operation outside of the environmental specifications for the product, or improper installation or maintenance.</p> <p>Kontron Embedded Modules GmbH will not be responsible for any defects or damages due to a faulty Kontron Embedded Modules GmbH product other than the products supplied by Kontron Embedded Modules GmbH.</p>

1.1	Introduction
	<p>The CRTtoLCD-5 is a highly integrated TFT panel interface controller, which allows an easy adaptation of standard video input sources like DVI or analog RGB to a digital TFT panel. The CRTtoLCD-5 need only one single 12V DC power supply and incorporates all needed functionality to build up a full featured TFT monitor. The card generates the necessary power sequencing for the flat screen. The highly flexible architecture of the CRTtoLCD-5 panel interface allows adapting nearly any available TFT panel. Therefore a variety of panel adapters and programming are available on request.</p>
1.2	Technical Information Summary
	<p>Features</p> <ul style="list-style-type: none"> - Zoom (from VGA) and shrink (from UXGA) scaling - Integrated 8-bit triple-channel ADC / PLL - Integrated Ultra-Reliable DVI™ 1.0 compliant receiver - embedded Microcontroller with serial ROM Interface - On-chip versatile OSD engine - All system clocks synthesized from a single external crystal - Programmable gamma correction (CLUT) - RealColor control provide sRGB compliance - Adjustable back light intensity control - Light sensor input - Independent Panel Power supply - Low EMI and power saving features <p>High-Quality Advanced Scaling</p> <ul style="list-style-type: none"> - Fully programmable zoom ratios - High quality shrink capability from UXGA resolution - RealRecovery function provides full color recovery image for refresh rates higher than those supported by the LCD panel - Moiré cancellation <p>Analog RGB Input Port</p> <ul style="list-style-type: none"> - Supports up to SXGA at 75Hz / UXGA 60 Hz <p>Auto-Configuration / Auto-Detection</p> <ul style="list-style-type: none"> - Phase and image positioning - Input format detection - Compatibility with all graphic cards and standard VESA modes <p>Ultra-Reliable DVI Compliant Input Port</p> <ul style="list-style-type: none"> - Operating up to 165 MHz (up to UXGA 60 Hz) - Direct connect to all DVI compliant digital transmitters

1.2	Technical Information Summary
	<p>RealColor Technology</p> <ul style="list-style-type: none"> - Digital brightness and contrast controls - TV color controls including hue and saturation control - Flesh tone adjustment - Full color matrix allows end users to experience the same color as viewed on CRTs and other displays (e.g. sRGB compliance) <p>LVDS Output Format</p> <ul style="list-style-type: none"> - Single / double channel up to SXGA 75 Hz output - Support for 8 or 6-bit panels (with high quality dithering) - One or two pixel output format <p>TTL Output Format</p> <ul style="list-style-type: none"> - Digital RGB panel 18-Bit interface <p>On-chip OSD Controller</p> <ul style="list-style-type: none"> - On-chip RAM for downloadable menus - 1,2 and 4-Bit per pixel character cells - Horizontal and vertical stretch of OSD menus - Blinking, transparency and blending - Proportional fonts <p>Display Interface Features :</p> <ul style="list-style-type: none"> - Control signal generation for backlight inverter - backlight dimming support - voltage generation and power sequence control for panel - Flat screens can be used with either 3.3V, 5V or 12V. - Digital RGB panel 18-Bit interface (optional) - LVDS panel interface (one and double port up to 24 Bit) <p>Operating Features :</p> <ul style="list-style-type: none"> - 5 or 6 (optional) button user interface - On Screen Display (OSD) control for full features - Full multi sync capable - VESA DPMS and DDC2B support - Single voltage supply (+12V DC) - No software drivers needed!

1.3	Connectors		
1.3.1	RGB analog input	CN2	
1.3.2	OSD keypad connector	CN500 or CN501 *Note1	
1.3.3	Backlight connector	CN101, CN102 *Note1	
1.3.4	Serial Port connector	CN200	
1.3.5	KAB-FLEX32 Interface	CN400 *Note1	
1.3.6	KAB-JILI30-Interface	CN100 *Note1	
1.3.7	DC Power supply	CN300, CN301	
1.3.8	Flatpanel power supply configuration	JP102	
1.3.9	Backlight control configuration	JP100, JP101	
1.3.10	ADC Input connector	CN201	
1.3.11	DVI input connector	CN1	

***Note1** can vary. Depends on version of CRTtoLCD-5

1.3.1		RGB Analog Input CN2		
High Density Sub-D-Connector 15 Contacts, Receptacle				
Case/Size : Right Angle, Through Hole				
	Name	Pin		Description
	RED	1	0	analog input red
	GREEN	2	0	analog input green
	BLUE	3	0	analog input blue
	NC	4	0	Not connected
	GND	5	0	Analog Ground
	GND	6	0	Analog Ground red
	GND	7	0	Analog Ground green
	GND	8	0	Analog Ground blue
	DDC+5V	9	0	Supply Voltage for DDC
	GND	10	0	Analog Ground
	NC	11	0	Not connected
	DDC_SDA	12	0	DDC serial data
	HSYNC	13	0	Horizontal sync input
	VSYNC	14	0	Vertical sync input
	DDC_SCL	15	0	DDC serial clock

1.3.2		OSD Keypad Connector CN501			
14 Contacts IDC Connector, Gold plated, double row, vertical mount, through hole					
Description	Name	Pin	Pin	Name	Description
+5V Keypad Power out	VCC	1	0 0	2	LED 2 LED Red *Note1
Keypad Button (Exit)	KEY	3	0 0	4	KEY Keypad Button (Menu)
Keypad Button (Right)	KEY	5	0 0	6	KEY Keypad Button (Left)
Transmit Data (TTL)	TXD	7	0 0	8	RXD Receive Data (TTL)
LED Green *Note1	LED 1	9	0 0	10	KEY Keypad Button (Power)
Not connected	NC	11	0 0	12	Vcc12 +12V Power Keypad out
Power Ground	GND	13	0 0	14	GND Power Ground

***Note1** Max. 4,5 mA output current

1.3.2	OSD keypad connector CN500		
Connector: Molex 53261-1490			
Matching Connector: Molex 51021-1400			
Connector Single Row, 14 contacts, Case/Size : Right Angle, 1,25mm Pitch			
Name	Pin	Description	
LED2	1 ○	LED Red *Note1	
LED1	2 ○	LED Green *Note1	
GND	3 ○	Key Power Ground	
KEY	4 ○	Key Button(Power)	
GND	5 ○	Key Power Ground	
KEY	6 ○	Key Button(Menu)	
KEY	7 ○	Key Button(Right)	
NC	8 ○	Not Connected	
NC	9 ○	Not Connected	
KEY	10 ○	Key Button(Left)	
KEY	11 ○	Key Button(Exit)	
KEY	12 ○	Key Button(Autoadjust)	
GND	13 ○	Power Ground	
VDD	14 ○	+ 3.3 V Keypad Power out	
Key Active = Button connected to Power Ground			

***Note1** Max. 4,5 mA output current

1.3.3	Backlight Connector CN102		
Connector: Molex 53261-0790			
Matching Connector: Molex 51021-0700			
Connector Single Row, 7 Contacts, Case/Size : Right Angle, 1,25mm Pitch			
Pin	Name	Description	
○	1	NC	
○	2	BKL TADJ	
○	3	GND	
○	4	Backlight power supply	
○	5	Backlight power supply	
○	6	GND	
○	7	BLON	
<div style="display: flex; justify-content: space-between;"> Not connected analog 0V to +5V or 0V to +12V (refer JP101) </div> <div style="display: flex; justify-content: space-between;"> Power Ground Typ. +12V (Note same as DC Input Voltage , </div> <div style="display: flex; justify-content: space-between;"> 1Amp. Per Contact allowed) </div> <div style="display: flex; justify-content: space-between;"> Power Ground Power Ground </div> <div style="display: flex; justify-content: space-between;"> Backlight control signal (TTL, refer to JP100) Polarity settings </div>			



1.3.3	Backlight Connector CN101		
Connector: Molex 53261-1090 Matching Connector: Molex 51021-1000 Connector Single Row, 10 Contacts, Case/Size : Right Angle, 1,25mm Pitch			
	Pin	Name	Description
		1 BLON 2 GND 3 GND 4 Backlight power supply 5 Backlight power supply 6 Backlight power supply 7 Backlight power supply 8 GND 9 GND 10 BKLTADJ	Backlight control signal (TTL, refer to JP100) Power Ground Power Ground Typical. +12V (Note same as DC Input Voltage , 1 Ampere per contact allowed) Power Ground Power Ground analog 0V to +5V or 0V to +12V (refer to JP101)



1.3.4	Serial Port connector CN200		
The OSD (On Screen Display) can be controlled either trough the keypad or the serial connector CN500/501 for configuration purposes or mass production. See also chapter 1.8 for detailed description. Caution ! The transmit and receive signals have TTL level!			
Connector: Molex 53261-0490 Matching Connector: Molex 52021-0400			
		Pin	Name
		1 2 3 4	VCC RXD TXD GND
			Description
			+5V DC Power (output) Receive Data Signal Transmit Data Signal Power Ground



1.3.5	KAB-FLEX32-Interface CN400 This connector directly matches through an interface cable for 31/41 pin VGA/SVGA TFT interface. All flat screen signals are LVTTTL compatible (3.3V)					
Flatfoil Connector 32 Contacts, Right Angle, Bottom Contact Case/Size : 0,5mm Pitch, ZIF						
Description	Name	Pin	Pin	Name	Description	
Power Ground	GND	1	O O	2	SCLK	Data clock
Latch pulse	LP	3	O O	4	FLM	First Line Marker
Power Ground	GND	5	O O	6	P0	Panel Data R0
Panel Data RED1	P1	7	O O	8	P2	Panel Data RED2
Panel Data RED3	P3	9	O O	10	P4	Panel Data RED4
Panel Data RED5	P5	11	O O	12	GND	Power Ground
Panel Data GREEN0	P6	13	O O	14	P7	Panel Data GREEN1
Panel Data GREEN2	P8	15	O O	16	P9	Panel Data GREEN3
Panel Data GREEN4	P10	17	O O	18	P11	Panel Data GREEN5
Power Ground	GND	19	O O	20	P12	Panel Data BLUE0
Panel Data BLUE1	P13	21	O O	22	P14	Panel Data BLUE2
Panel Data BLUE3	P15	23	O O	24	P16	Panel Data BLUE4
Panel Data BLUE5	P17	25	O O	26	GND	Power Ground
Data Enable	MOD (DE)	27	O O	28	Panel_VCC	Panel Power *Note1
Panel Power *Note1	Panel_VCC	29	O O	30	R/L	Right/Left
Up/Down rotate	U/D	31	O O	32	NC	Not connected
*Note1: Refer to JP102 how to configure the panel power						



1.3.6	KAB-JILI30-Interface CN100			
	Connector: JAE FI-X30S-HF Matching Connector: JAE FI-X30H			
	Name	Pin	Description	
	FTX0-	1	0	Even Receiver Signal
	FTX0+	2	0	Even Receiver Signal
	FTX1-	3	0	Even Receiver Signal
	FTX1+	4	0	Even Receiver Signal
	FTX2-	5	0	Even Receiver Signal
	FTX2+	6	0	Even Receiver Signal
	GND	7	0	Power Ground
	FTXC-	8	0	Even Clock Signal
	FTXC+	9	0	Even Clock Signal
	FTX3-	10	0	Even Receiver Signal
	FTX3+	11	0	Even Receiver Signal
	STX0-	12	0	Odd Receiver Signal
	STX0+	13	0	Odd Receiver Signal
	GND	14	0	Power Ground
	STX1-	15	0	Odd Receiver Signal
	STX1+	16	0	Odd Receiver Signal
	GND	17	0	Power Ground
	STX2-	18	0	Odd Receiver Signal
	STX2+	19	0	Odd Receiver Signal
	STXC-	20	0	Odd Clock Signal
	STXC+	21	0	Odd Clock Signal
	STX3-	22	0	Odd Receiver Signal
	STX3+	23	0	Odd Receiver Signal
	GND	24	0	Power Ground
	NC	25	0	Not Connected
	PPWR	26	0	Controls Panel Digital Power
	NC	27	0	Not Connected
	PANEL_VCC	28	0	Panel Power (refer to JP102)
	PANEL_VCC	29	0	Panel Power (refer to JP102)
	PANEL_VCC	30	0	Panel Power (refer to JP102)

1.3.7	DC Power Supply CN300		
	Apply operating voltage using connector CN300 or CN301.		
	4 Contact Connector, Single Row, Right Angle, Polarization, through hole		
	Pin	Name	Description
	1	NC	Not connected
	2	GND	Power Ground
	3	GND	Power Ground
	4	+12V	+12 V DC Power Input

1.3.7	DC Power Supply CN301 Apply operating voltage using connector CN300 or CN301.													
DC POWER JACK, Case/Size : PCB-Mount 2mm Pin Diameter														
<table border="1" style="width: 100%; border-collapse: collapse;"> <thead> <tr> <th style="width: 30%;"></th> <th style="width: 10%;">Pin</th> <th style="width: 15%;">Name</th> <th style="width: 45%;">Description</th> </tr> </thead> <tbody> <tr> <td style="text-align: center;"></td> <td style="text-align: center;">1</td> <td style="text-align: center;">+12V</td> <td rowspan="2" style="text-align: center;">+12 V DC Power Input Power Ground</td> </tr> <tr> <td></td> <td style="text-align: center;">2</td> <td style="text-align: center;">GND</td> </tr> </tbody> </table>					Pin	Name	Description		1	+12V	+12 V DC Power Input Power Ground		2	GND
	Pin	Name	Description											
	1	+12V	+12 V DC Power Input Power Ground											
	2	GND												

1.3.8	Flatpanel Power Configuration JP102																														
Short pins 1-2 or 2-3 or leave open to choose required voltage supply. Caution ! Only one configuration for flatpanel is allowed, otherwise the board is permanently damaged.																															
Connector Single Row 2,54 mm, 3 Contacts, Gold plated Case/Size : Vertical, Through Hole																															
<table border="1" style="width: 100%; border-collapse: collapse;"> <thead> <tr> <th style="width: 10%;"></th> <th style="width: 10%;">1</th> <th style="width: 10%;">2</th> <th style="width: 10%;">3</th> <th style="width: 10%;">Pin</th> <th style="width: 10%;">2-3</th> <th style="width: 10%;">1-2</th> <th style="width: 10%;">open</th> <th style="width: 10%;">Delivery Default</th> </tr> </thead> <tbody> <tr> <td style="text-align: center;"></td> <td></td> <td></td> <td></td> <td></td> <td style="text-align: center;">+12V</td> <td style="text-align: center;">+5V</td> <td style="text-align: center;">+3.3V</td> <td style="text-align: center;">1-2 closed</td> </tr> <tr> <td colspan="9" style="text-align: center;">Never unplug/replug while in use!</td> </tr> </tbody> </table>						1	2	3	Pin	2-3	1-2	open	Delivery Default						+12V	+5V	+3.3V	1-2 closed	Never unplug/replug while in use!								
	1	2	3	Pin	2-3	1-2	open	Delivery Default																							
					+12V	+5V	+3.3V	1-2 closed																							
Never unplug/replug while in use!																															

1.3.9	Backlight Control Configuration JP100																											
Use JP100 to control polarity of backlight control signal.																												
Connector Single Row 2,54 mm, 3 Contacts, Gold plated Case/Size : Vertical, Through Hole																												
<table border="1" style="width: 100%; border-collapse: collapse;"> <thead> <tr> <th style="width: 10%;"></th> <th style="width: 10%;">1</th> <th style="width: 10%;">2</th> <th style="width: 10%;">3</th> <th style="width: 10%;">Pin</th> <th style="width: 10%;">2-3</th> <th style="width: 10%;">1-2</th> <th style="width: 10%;">Delivery Default</th> </tr> </thead> <tbody> <tr> <td style="text-align: center;"></td> <td></td> <td></td> <td></td> <td></td> <td style="text-align: center;">/BLON</td> <td style="text-align: center;">BLON</td> <td style="text-align: center;">1-2 closed</td> </tr> <tr> <td colspan="8" style="text-align: center;">Never unplug/replug while in use!</td> </tr> </tbody> </table>						1	2	3	Pin	2-3	1-2	Delivery Default						/BLON	BLON	1-2 closed	Never unplug/replug while in use!							
	1	2	3	Pin	2-3	1-2	Delivery Default																					
					/BLON	BLON	1-2 closed																					
Never unplug/replug while in use!																												

1.3.9	Backlight Output Adjust Configuration JP101																											
Use JP101 to set correct backlight adjust range I-out 20mA max.																												
Connector Single Row 2,54 mm, 3 Contacts, Gold plated Case/Size : Vertical, Through Hole																												
<table border="1" style="width: 100%; border-collapse: collapse;"> <thead> <tr> <th style="width: 10%;"></th> <th style="width: 10%;">1</th> <th style="width: 10%;">2</th> <th style="width: 10%;">3</th> <th style="width: 10%;">Pin</th> <th style="width: 10%;">2-3</th> <th style="width: 10%;">1-2</th> <th style="width: 10%;">Delivery Default</th> </tr> </thead> <tbody> <tr> <td style="text-align: center;"></td> <td></td> <td></td> <td></td> <td></td> <td style="text-align: center;">Typ. 0-12V</td> <td style="text-align: center;">Typ. 0-5V</td> <td style="text-align: center;">1-2 closed</td> </tr> <tr> <td colspan="8" style="text-align: center;">Never unplug/replug while in use!</td> </tr> </tbody> </table>						1	2	3	Pin	2-3	1-2	Delivery Default						Typ. 0-12V	Typ. 0-5V	1-2 closed	Never unplug/replug while in use!							
	1	2	3	Pin	2-3	1-2	Delivery Default																					
					Typ. 0-12V	Typ. 0-5V	1-2 closed																					
Never unplug/replug while in use!																												

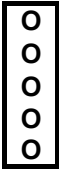
1.3.10	ADC Input Connector CN201 (Light Sensor Input)		
Connector: Molex 53261-0590 Matching Connector: Molex 52021-0500			
	Pin	Name	Description
	1	GND	Power Ground
	2	ADC1	ADC1 Input *Note1
	3	DVDD3.3	3.3V output source (max.50mA)
	4	ADC2	ADC2 Input *Note1
	5	GND	Power Ground

***Note1** Input range is 0 - 3V. Onboard pulled up to DVDD3.3 through 4, 7 KΩ resistor.

1.3.11	DVI-D Input Connector CN1				
This input supports the connection of DVI capable video cards and supports resolutions from 640x480 up to 1600x1200.					
Connector 24 Contacts, Gold plated Case/Size : Vertical, Through Hole					
Description	Name	Pin	Pin	Name	Description
Receiver Signal(-) (RX2-)	RX2-	1	0 0	2	RX2+ Receiver Signal(+) (RX2+)
Power Ground	GND	3	0 0	4	NC Not connected
Not connected	NC	5	0 0	6	SCL I ² C clock
I ² C Data	SDA	7	0 0	8	NC Not connected
Receiver Signal(-) (RX1-)	RX1-	9	0 0	10	RX1+ Receiver Signal(+) (RX1+)
Power Ground	GND	11	0 0	12	NC Not connected
Not connected	NC	13	0 0	14	+5V +5V from DVI video card
Power Ground	GND	15	0 0	16	HP Hot Plug
Receiver Signal(-) (RX0-)	RX0-	17	0 0	18	RX0+ Receiver Signal(+) (RX0+)
Power Ground	GND	19	0 0	20	NC Not connected
Not connected	NC	21	0 0	22	GND Power Ground
Clock Signal(+) (RXC+)	RXC+	23	0 0	24	RXC- Clock Signal(-) (RXC-)
Not connected	NC	C1	0 0	C2	NC Not connected
Not connected	NC	C3	0 0	C4	NC Not connected
Not connected	NC	C5	0 0	C5-1	NC Not connected

1.4	On Screen Display
	<p>With the OSD (On Screen Display) you can modify the settings and control the special features of the CRTtoLCD-5. The OSD uses a number of menus for making changes and turning the special features on or off. The configuration can be done via the OSD-keypad (OSD-Panel-Kit). To start the OSD press the "OSD" button on the keypad, after switching the power supply on. If a valid flat panel configuration is installed, the OSD Main Menu will be displayed.</p> <p>To select an tab, simply use the button "UP" or "DOWN" to move the cursor to the tab you want and press button "OSD". When you use the tab "Exit" and press the "CONFIRM"-button, the OSD will be closed.</p> <p>To use a tab menu, simply use "OSD"-button to select the field. Use "UP" or "DOWN" to select a value for that field. The "Exit"-field on the bottom-side on the tab will go up to the tab-selection. Simply press the "OSD"-button.</p>

Note: All changed values will only be saved by selecting "Exit" from the OSD. If not, the adjusted values will be lost after loss of power.

Input Select

Feature	Button	Description
Select VGA	Press "Osd"	Select VGA input
Select DVI	Press "Osd"	Select DVI input
Exit	Press "Osd"	Exit menu

Brightness

Feature	Button	Description
Brightness	Press "Osd" to enter Adjust with "Up" and "Down"	Adjust brightness
Contrast	Press "Osd" to enter Adjust with "Up" and "Down"	Adjust contrast
Backlight Brightness	Press "Osd" to enter Adjust with "Up" and "Down"	Adjust backlight brightness
Backlight Mode	Use "Up" and "Down"	Enter Backlight Mode submenu
- Manual Backlight	Use "Up" and "Down"	Control backlight over the OSD
- External Backlight Control	Use "Up" and "Down"	Enable external control of backlight
- Exit		Exit submenu
Exit	Press "Osd"	Exit menu

Color Settings

Feature	Button	Description
Auto Color Adjust	Press "Osd"	Adjust colors automatically
Switch sRGB Mode	Press "Osd"	Switch to sRGB mode
Color Temperature	Press "Osd"	Enter Color Temperature submenu
- Select Color Temperature	Press "Osd"	Select predefined color temperatures
- Adjust RGB Values	Press "Osd"	Enter Adjust RGB Values submenu
- Red Color Value	Use "Up" and "Down"	User defined value of color temperature
- Green Color Value	Use "Up" and "Down"	User defined value of color temperature
- Blue Color Value	Use "Up" and "Down"	User defined value of color temperature
- 4200K	Press "Osd"	Set predefined color temperature of 4200K
- 5000K	Press "Osd"	Set predefined color temperature of 5000K
- 6500K	Press "Osd"	Set predefined color temperature of 6500K
- 7500K	Press "Osd"	Set predefined color temperature of 7500K
- 9300K	Press "Osd"	Set predefined color temperature of 9300K
- Exit	Press "Osd"	Exit submenu
Exit	Press "Osd"	Exit menu

Image Settings

Feature	Button	Description
Auto Adjust	Press "Osd"	Adjust image automatically
Adjust Width	Press "Osd" to enter Adjust with "Up" and "Down"	Adjust image width
Adjust Phase	Press "Osd" to enter Adjust with "Up" and "Down"	Adjust image phase
Horizontal Pos	Press "Osd" to enter Adjust with "Up" and "Down"	Adjust image horizontal position
Vertical Pos	Press "Osd" to enter Adjust with "Up" and "Down"	Adjust image vertical position
Exit	Press "Osd"	Exit menu

Tools

Feature	Button	Description
OSD Settings	Press "Osd"	Enter OSD Settings submenu
- OSD Timeout	Use "Up" and "Down"	Set the OSD time to close automatically
- OSD Hor. Position	Use "Up" and "Down"	Set OSD horizontal position
- OSD Ver. Position	Use "Up" and "Down"	Set OSD vertical position
- OSD Orientation	Press "Osd"	Enter OSD Orientation submenu
- Standard	Press "Osd"	OSD standard orientation
- Rotate 90	Press "Osd"	Set OSD orientation at 90 degrees
- Rotate 180	Press "Osd"	Set OSD orientation at 180 degrees
- Rotate 270	Press "Osd"	Set OSD orientation at 270 degrees
- Horizontal Mirror	Press "Osd"	View the OSD horizontally mirrored
- Exit		Exit submenu
Factory Reset	Press "Osd"	Recall all default factory settings
Factory Color Reset	Press "Osd"	Recall the factory default color settings
Factory Position Reset	Press "Osd"	Recall the factory default position of screen
Sharpness	Use "Up" and "Down"	Adjust level of sharpness
Overlapped Mode Select	Press "Osd"	Select overlapped mode
Exit	Press "Osd"	Exit menu

Exit OSD Menu

Feature	Button	Description
Exit	Press "Osd"	Exit the OSD and save changes

1.5	Technical Specification
	<p>These values were measured with OSD-Panel attached and without flatpanel and backlight inverter.</p> <p>- Supply voltage at 25°C without load:</p> <p>Minimum supply voltage : + 11,4 V DC Typical supply voltage : + 12,0 V DC Absolute Maximum supply voltage : + 12.6 V DC</p> <p>- Typical Input current at 25°C without load:</p> <p>CRTtoLCD-5 with input signal (XGA) : 250 mA CRTtoLCD-5 with power down typical : 60 mA</p> <p>- Input Supply voltage ripple : typical 100 mV peak to peak 0 – 20 MHz</p> <p>- Current Rating of Flatpanel Power supply:</p> <p>PANEL VCC Steady State 3V / 5V and 12V @ +5% : 3A PANEL VCC 5sec. -5% 3V3 @4,33A PANEL VCC 5sec. -5% 5V @ 4,15A PANEL VCC 5sec. -2% 12V @ 4A Note: Output power without any switch or short circuit breaker</p> <p>- Slewrate of Flatpanel Power supply with 3A load</p> <p>PANEL VCC 3V3 302us PANEL VCC 5V 408us PANEL VCC 12V 1.7ms</p> <p>- Voltage and Current Rating of Backlight Power supply:</p> <p>Direct +12V Output voltage without any switch or short circuit breaker CN400: Maximum output current 4A CN401: Maximum output current 2A There are no limitations between Backlight Power and Flatpanel Power The only limitation is the capability of the DC Input Power supply</p> <p>VGA connector signals : Sync input voltage low : 0.8 V Sync input voltage high : 2.4 V RGB input voltage : 0 – 0.7 V with 75 Ohm external termination RGB input current : 0 – 5 mA</p> <p>- Temperature : ambient : 0° C – 60° C (*1) Non operating : - 10° C – 85° C (*1) The maximum temperature on the module surface can exceed above mentioned ambient temperature. It is the user responsibility to keep this temperature within the above specification.</p> <p>- Thermal gradient : operating : 25° C per hour non-operating : 40° C per hour</p> <p>- Relative Humidity : operating : 10% - 90 % RH non-condensing non operating : 5% - 95% RH non-condensing</p>

1.5	Technical Specification
	<p>- Mechanical : Shock : 50G/20ms square wave maximum Vibration : 1G/0-600Hz, dwell not to exceed</p> <p>- Altitude : operating : 0 – 3000 m non-operating : 0 – 5000 m</p> <p>- Dimensions of the printed circuit board :</p> <p style="padding-left: 40px;">Width : 114.28 mm Length : 179.07 mm Thickness : 1.50 mm</p> <p>- Dimensions of the module :</p> <p style="padding-left: 40px;">Width : 119.50 mm Length : 179.07 mm Height : 16.50 mm +2mm (*)</p> <p>Note : The dimension of the module can change if cable, Adapter or Keypad plugged in!</p>

1.6 Supported Video Modes (Analog Input)		
Generally all VESA compatible video modes are supported. If modes are not supported the controller displays "Invalid Mode" on the flat panel. In this case use the Flat Panel Editor, available on request, to add this special mode to the supported mode table.		
Following modes are tested		
Video Mode Input	Vertical refresh rate	Mode standard
720 x 400	70 Hz	DOS
640 x 350	70 Hz	DOS
640 x 400	70 Hz	DOS
640 x 480	59,9 Hz	VGA
640 x 480	60 Hz	VGA
640 x 480	72 Hz	VGA
640 x 480	72,8 Hz	VGA
640 x 480	75 Hz	VGA
800 x 600	56,25 Hz	SVGA
800 x 600	60 Hz	SVGA
800 x 600	70 Hz	SVGA
800 x 600	72 Hz	SVGA
800 x 600	75 Hz	SVGA
1024 x 768	60 Hz	XGA
1024 x 768	70 Hz	XGA
1024 x 768	72 Hz	XGA
1024 x 768	75 Hz	XGA
1152 x 864	60 Hz	
1152 x 864	70 Hz	
1152 x 864	75 Hz	
1280 x 1024	60 Hz	SXGA
1280 x 1024	70 Hz	SXGA
1280 x 1024	75 Hz	SXGA
1600 x 1200	60 Hz	UXGA

1.6 Supported Video Modes (DVI Input)		
Generally all VESA compatible video modes are supported. If modes are not supported the controller displays "Invalid Mode" on the flat panel. In this case use the Flat Panel Editor, available on request, to add this special mode to the supported mode table.		
Following modes are tested		
Video Mode Input	Vertical refresh rate	Mode standard
640 x 480	60 Hz	VGA
800 x 600	60 Hz	SVGA
1024 x 768	60 Hz	XGA
1280 x 1024	60 Hz	SXGA

1.7	Layout/Schematics
------------	--------------------------

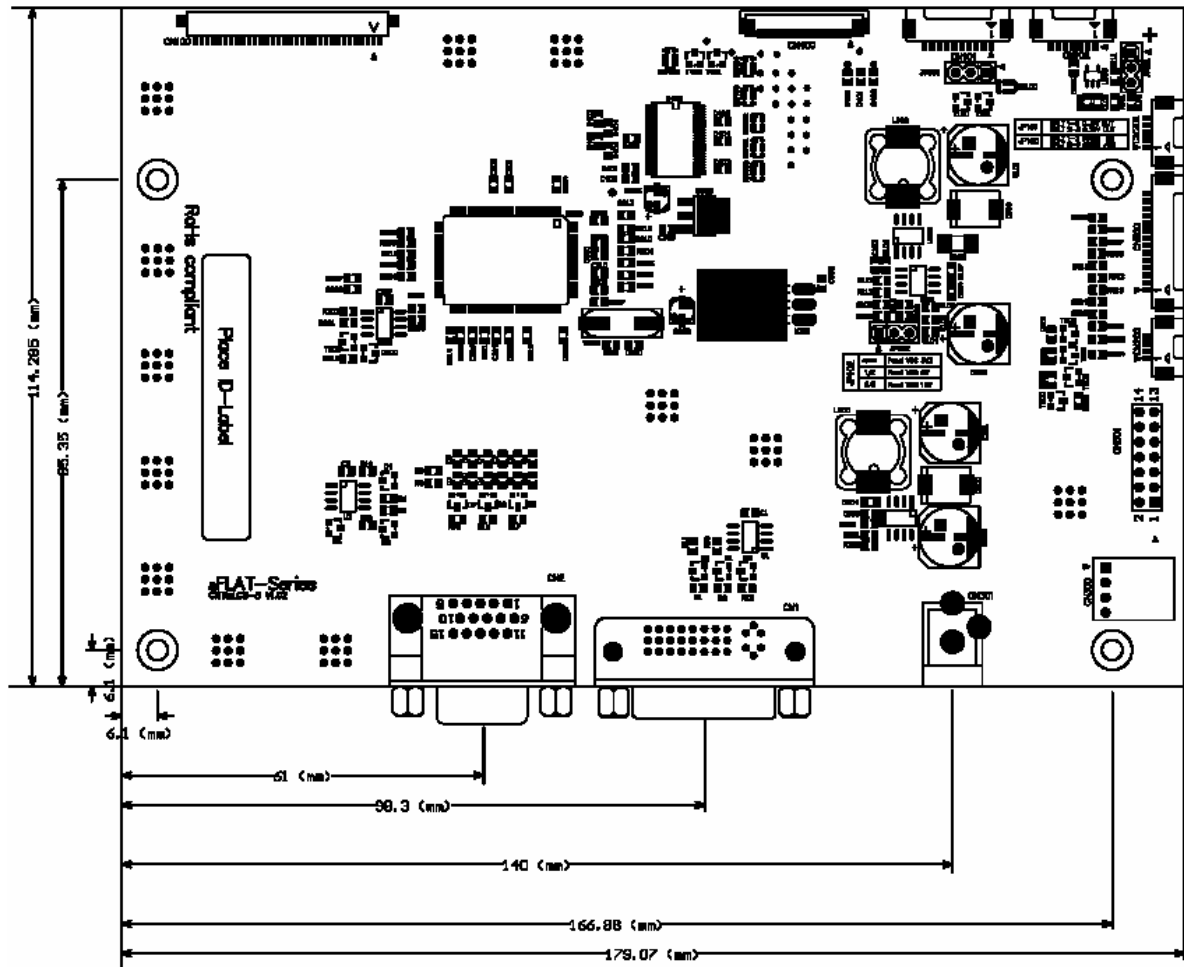

CRTfoLCD-5

1.7 Layout/Schematics

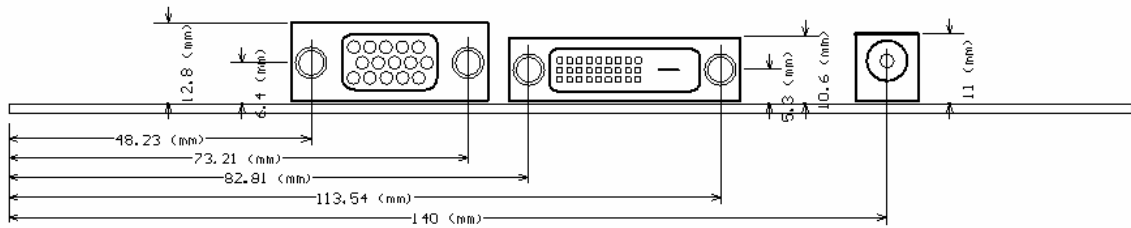

OSD-Keypad "OSD-Panel"

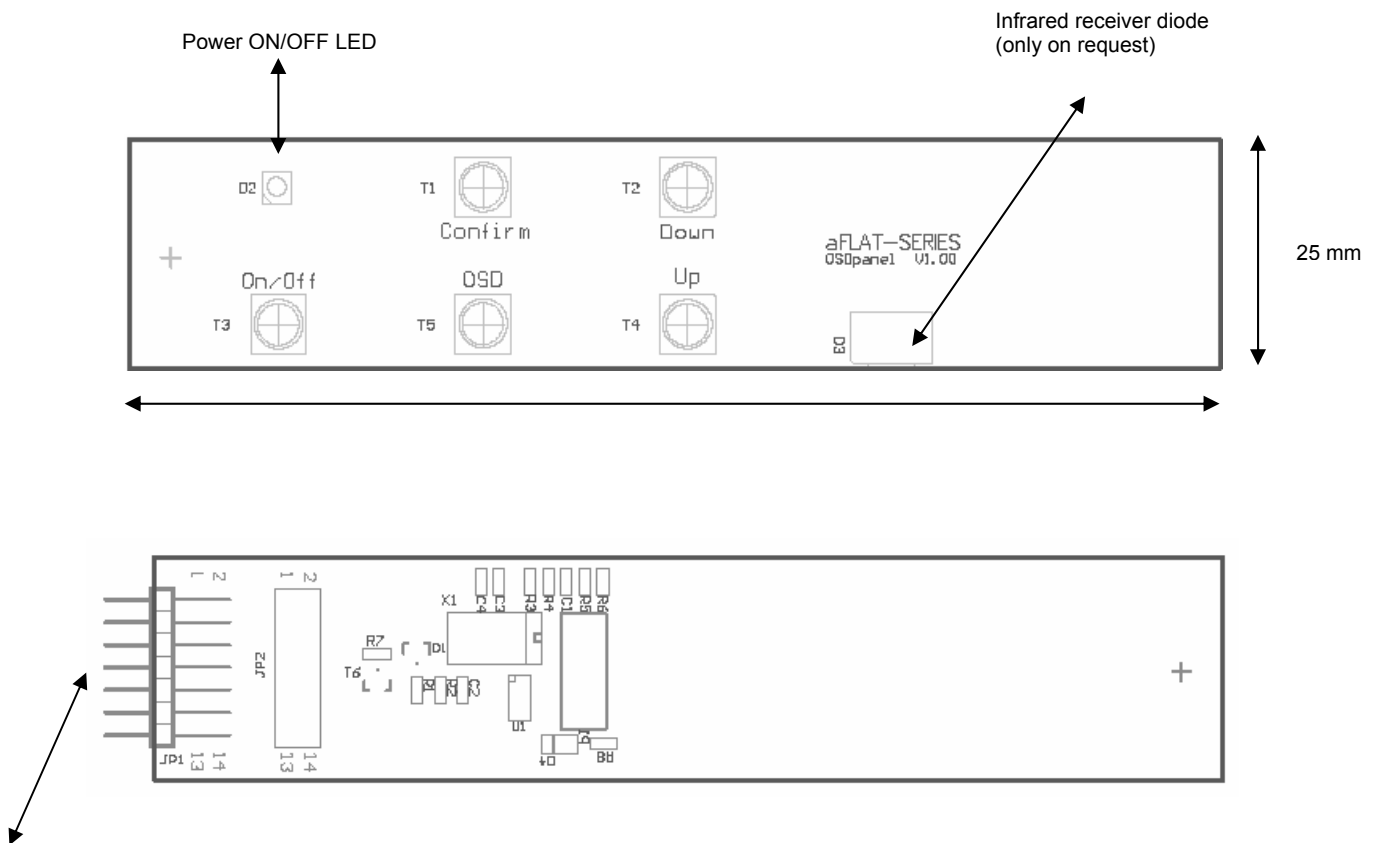

Keypad JP1 connected to CN501 of CRTtoLCD-5!

1.8	Serial OSD
	coming soon ...

1.9	Technical Support
	<p>Please report any errors or problems to this email address: sales_graphic@kontron.com.</p> <p>Normally, there is no telephone support. In your email message, please include the following information :</p> <ul style="list-style-type: none">Company NameYour NameAddressEmailTelephone/FaxExact description of the hardware, etc.Exact description of the software used (for example: Win XP with driver XYZ)Exact description of the error.

2.0	Revision History		
Date	Author	Version	Description
26.06.2003	D.Finstel	1.0	Initial release
11.06.2004	M. Schulze	1.1	Updated specs
01.06.2005	L.Trotter	1.2	Change specs for new release
07.06.2005	V. Irion	1.3	Added supported video modes and OSD description
04.10.2005	V. Irion	1.4	Updated supported video modes Updated connector CN201 and layout to version 1.02